

The 4" Mini-Bollard features lighting performance comparable to most 8" diameter 70 watt metal halide products using only 20 watts. This much smaller, less obtrusive fixture provides less glare, more uniformity and the same spacing, using less than 1/3 the energy. IP68 pressure-tight sealed lamp/optical chamber prevents moisture, dirt, soot, bugs etc. from entering and degrading the optical performance. It features a column/compression engineered structure resulting in an extremely durable bollard. The mini bollard features a unique tool-less re-lamping system, yet maintains a high degree of vandal resistance with no visible fasteners/hardware of any kind, assuring long life and trouble free performance in the most demanding environments.

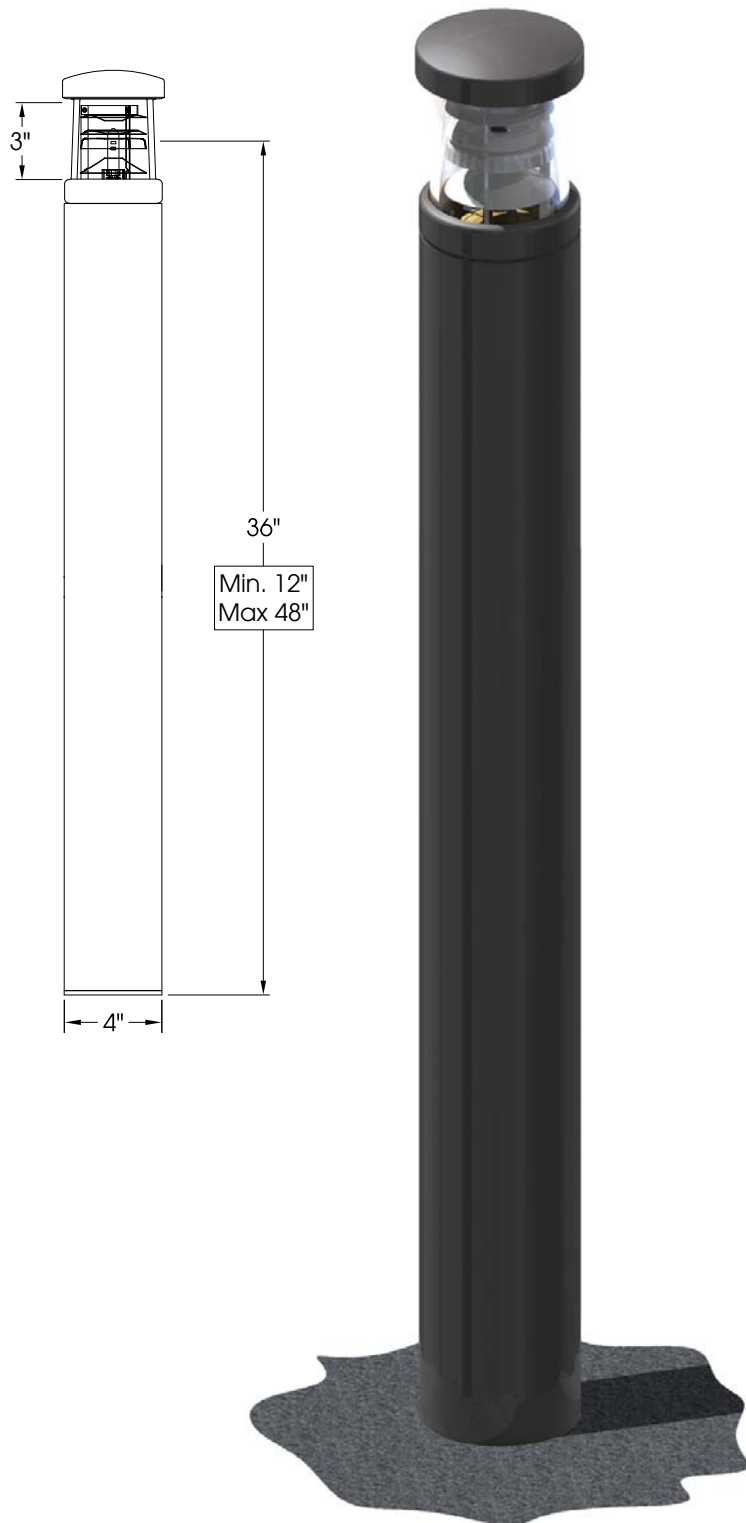

Specifications/Features:

Enclosure Material: Low copper aluminum alloys, 6063 extruded housing and A356 cast components.

Lens: Pressed/molded glass, 1/4" thick, chemically strengthened to a rupture stress greater than 300 N/mm², and resistant to 100°C thermal shock.

Gaskets: High temperature silicone seals resistant to ozone, and UV degradation in the lamp and ballast chambers.

Optical Assembly: Spun high purity 1100 aluminum, physically polished and bright anodized reflective surfaces with high temperature blackpaint on non-reflective surfaces to reduce glare. Factory sealed in the optical chamber. Re-lamp access through o-ring sealed bottom port eliminates need to ever break the glass/metal bond.

Socket: Porcelain, with nickel plated contacts, 4kV pulse rated, with Teflon leads.

Ballast: Electronic, High power factor (>.95), 50-60 Hz input, 170 Hz square-wave output, <20% THD, minus 15°C starting, <4.5W ballast loss, auto shut-off at EOL and short circuit conditions, FCC 18C EMI compliance.

Ballast Enclosure: Fully epoxy encapsulated aluminum ballast enclosure, easily field replaceable, provides a completely IP68 sealed ballast and exceptionally cool operation for greatly extended ballast life. TC point temperature measurement less than 55°C on 80°C rated ballast.

Mounting/field wiring: Three 3/8" x 12" stainless steel L-hook anchor bolts, each with 2 nuts and washers, heavy sand cast red brass base-plate casting has 3 openings for 1/2" conduit to pass through and stub up above grade minimum 6" within bollard enclosure, which provides space for field wiring and through branch circuiting.

Finish: Premium quality thermoset polyester powdercoat for a durable finish in the following:

- GRN** - Green
- CLB** - Classic Bronze
- BLK** - Satin Black
- BCT** - Brushed and Clear Coat

IP68 Rated

4" Mini Bollard - Aluminum

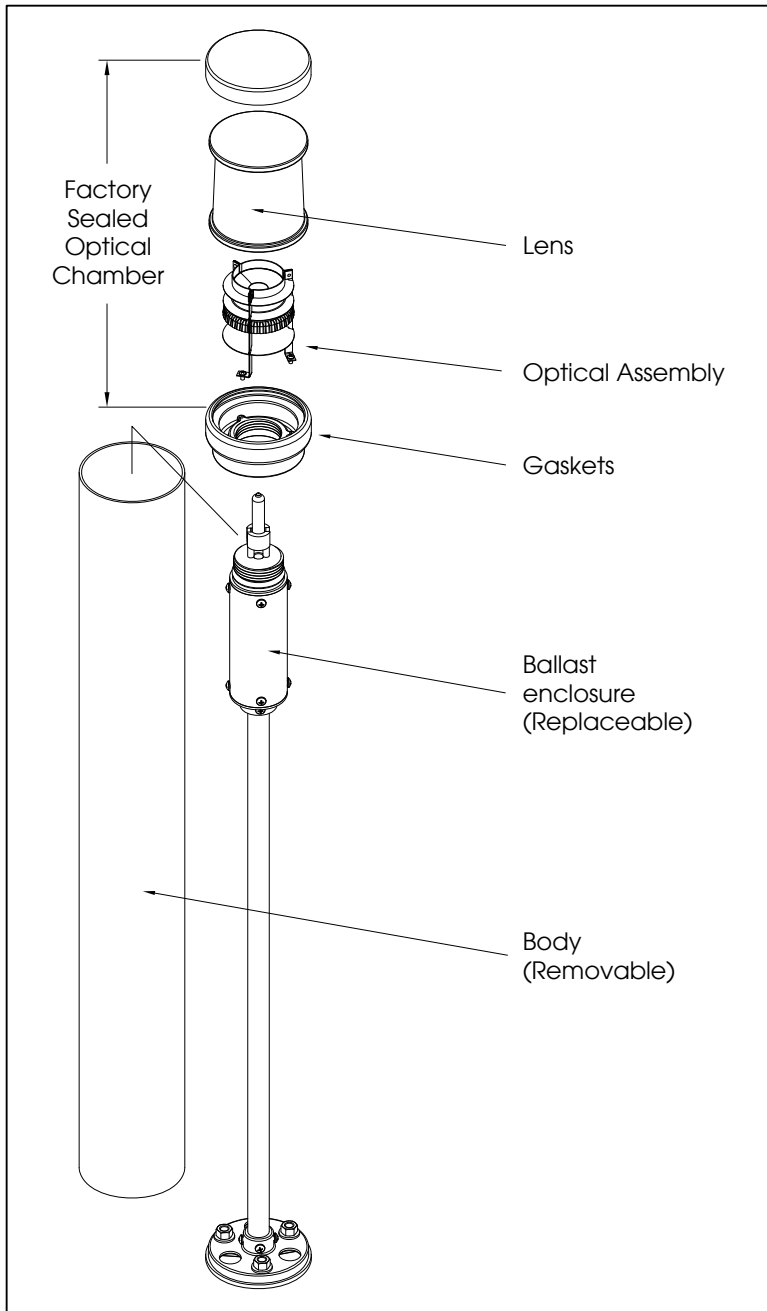

Optical Chamber View

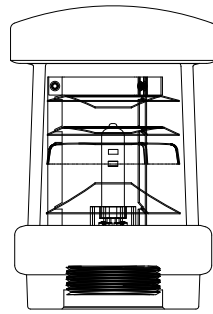

Anchorage Details

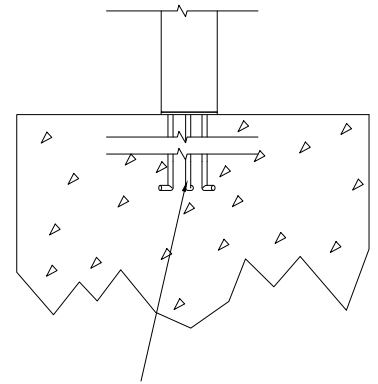

Three 3/8" x 12" stainless steel L-hook anchor bolts, each with 2 nuts and washers, heavy sand cast aluminum base-plate casting has 3 openings for 1/2" conduit to pass through and stub up above grade minimum 6" within bollard enclosure, which provides space for field wiring and through branch circuiting.

Polar

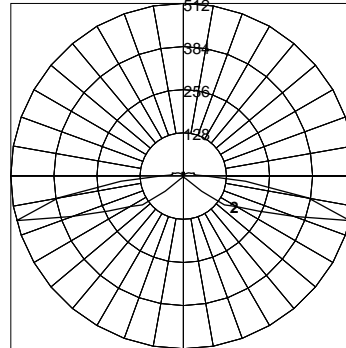

Iso-curve

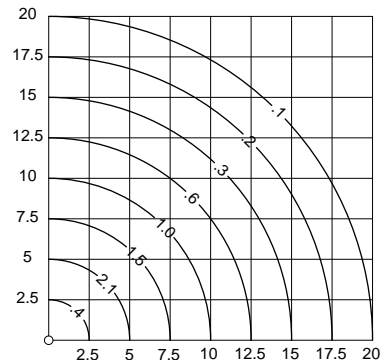

ORDERING INFORMATION:

Model (Description)	Finish	Light Source Metal Halide	Voltage	Light Center
DMB4A (4" Aluminum)	GRN CLB BLK BCT Custom Color Specify	20MH T-4 GU6.5 BASE 39MH BT-5 PGJ5 BASE (120V ONLY)	120 277	STD 36" MIN 12" CSTM _____ MAX 48"

Sample: DMB4A / TBK / I20MH / 120 / 24"

Part # DMB4A / / / /