

The 2.5" Micro-Bollard features lighting performance comparable to most 50 watt metal halide 8" diameter products using only 20 watts. This much smaller, less obtrusive fixture provides less glare, more uniformity and the same spacing, using less than 1/2 the energy. An IP68 pressure-tight sealed lamp/optical chamber prevents moisture, dirt, soot, bugs etc. from entering and degrading the optical performance. It features a column/compression engineered structure resulting in an extremely durable bollard. The micro bollard features a unique tool-less re-lamping system, yet maintains a high degree of vandal resistance with no visible fasteners/hardware of any kind, assuring long life and trouble free performance in the most demanding environments.

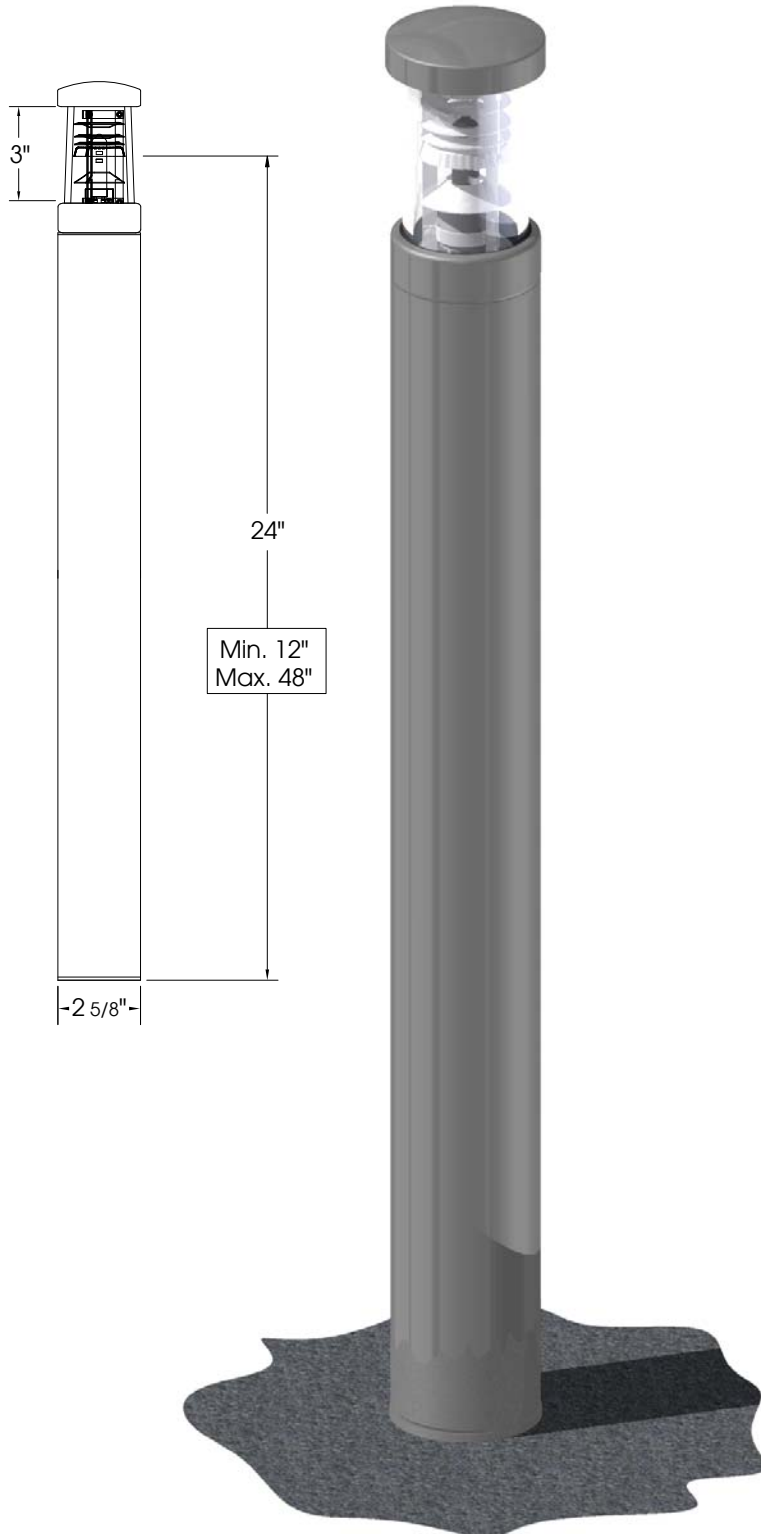

Specifications/Features:

Enclosure Material: Stainless Steel housing tube and visible top cap casting, 304 alloy standard, 316 available on special order). Internal cast components are machined red brass.

Lens: Pressed/molded glass, 1/4" thick, chemically strengthened to a rupture stress greater than 300 N/mm², and resistant to 100°C thermal shock.

Gaskets: High temperature silicone seals resistant to ozone, and UV degradation in the lamp and ballast chambers, neoprene rubber in the junction box enclosure.

Optical Assembly: Spun high purity 1100 aluminum, physically polished and bright anodized reflective surfaces with high temperature black paint on non-reflective surfaces to reduce glare. Factory sealed in the optical chamber. Re-lamp access through o-ring sealed bottom port eliminates need to ever break the glass/metal bond.

Socket: Porcelain, with nickel plated contacts, 4kV pulse rated, with Teflon leads.

Ballast: Electronic, High power factor (>.95), 50-60 Hz input, 170 Hz square-wave output, <20% THD, minus 15° C starting, <4.5W ballast loss, auto shut-off at EOL and short circuit conditions, FCC 18C EMI compliance.

Ballast Enclosure: Fully epoxy encapsulated brass ballast enclosure, easily field replaceable, provides a completely IP68 sealed ballast and exceptionally cool operation for greatly extended ballast life. TC point temperature measurement less than 55°C on 80°C rated ballast.

Mounting/field wiring: Subterranean, thick-walled sand cast aluminum junction box with two, 1/2" NPT threaded conduit openings in bottom standard, with access for wiring and inspection from above ground, provides exceptional mounting rigidity when poured in concrete, and capacity for through-branch wiring.

Finish: Natural brushed 120 grit

IP68 Rated

2.5" Micro Bollard - Stainless Steel

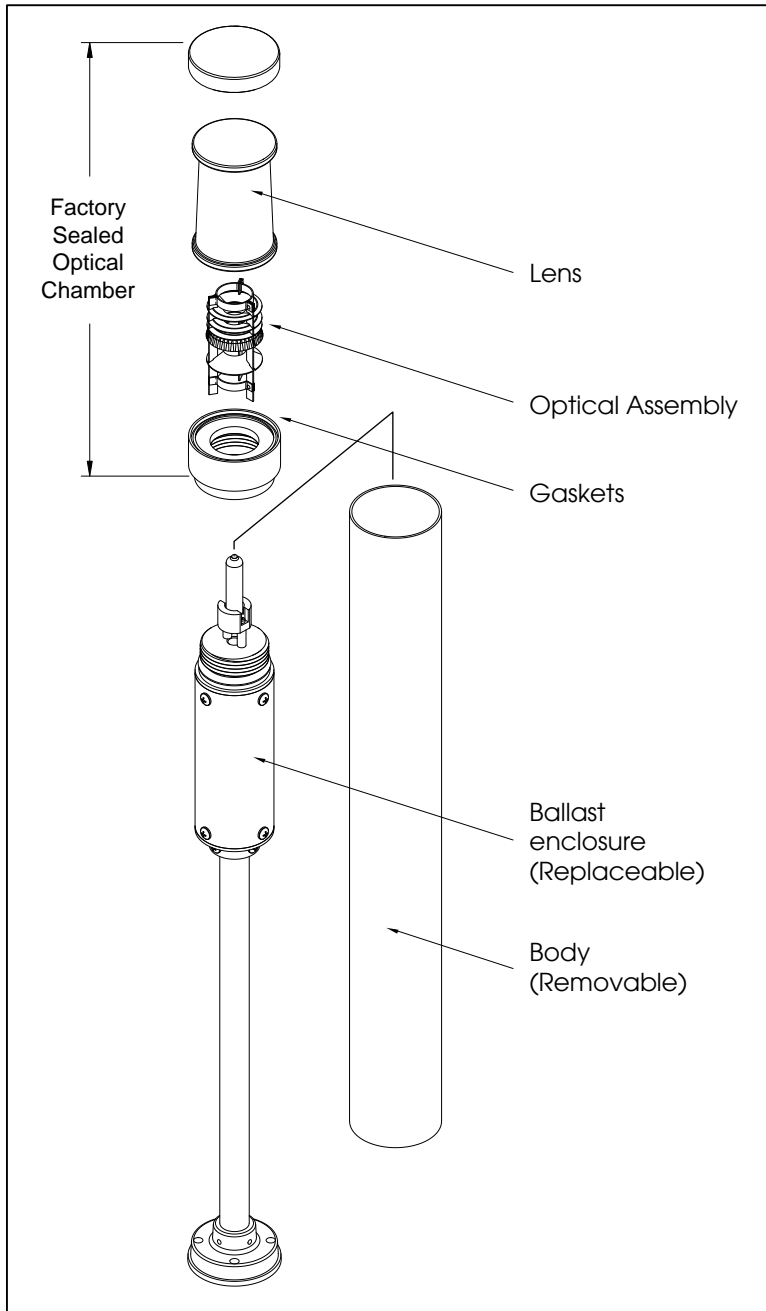

Optical Chamber View

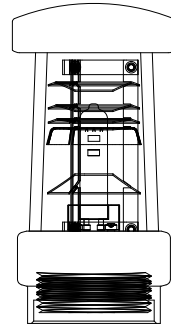

Anchorage Details

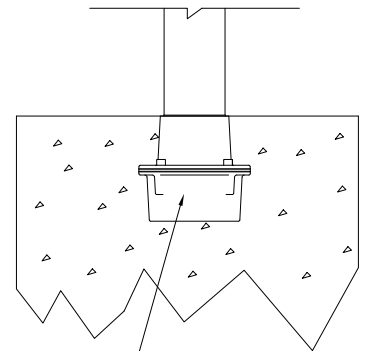

Subterranean, thick-walled sand cast brass junction box with two, 1/2" NPT threaded conduit openings in bottom standard, with access for wiring and inspection

Polar

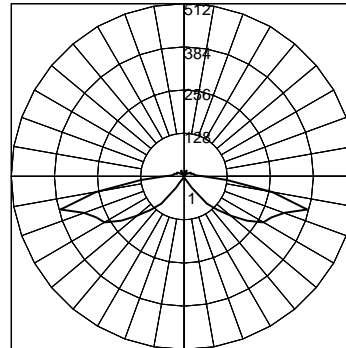

Iso-curve

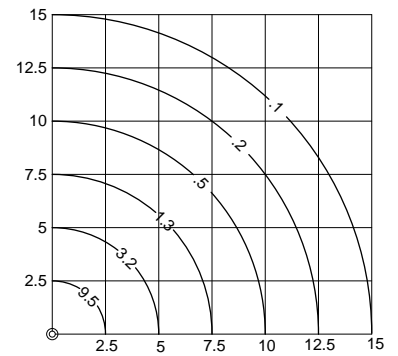

ORDERING INFORMATION:

Model (Description)	LIGHT SOURCE Metal Halide	VOLTAGE	LIGHT CENTER
DMB2.5SS (2.5" Stainless Steel)	20MH T-4 GU6.5 BASE	120 277	STD 24" MIN 12" CSTM _____ MAX 48"

Sample: **DMB2.5SS / 20MH / 120 / 24"**

Part # **DMB2.5SS / / /**

5220 Shank Rd Pearland, Texas 77581
 T: (281)997-5400 F: (281)997-5441
 Toll Free: (800)364-0098

www.amerluxexterior.com

amerlux
GLOBAL LIGHTING SOLUTIONS
exterior